



Canadian Hydrogen Convention
April 22-24, 2025 | Edmonton, Canada

Stand Rules, Regulations, Health & Safety



hydrogenexpo.com

#CHC2025

dmg::events

BUILDING INFORMATION

The following height and weight restrictions apply:

Location	Ceiling Height	Loading Door Dimensions	Floor Limit
Halls A, B & C	29ft (348 m)	16' H x 15' 9" W (4.5m H x 4.8m W)	350 lbs./sq. ft.

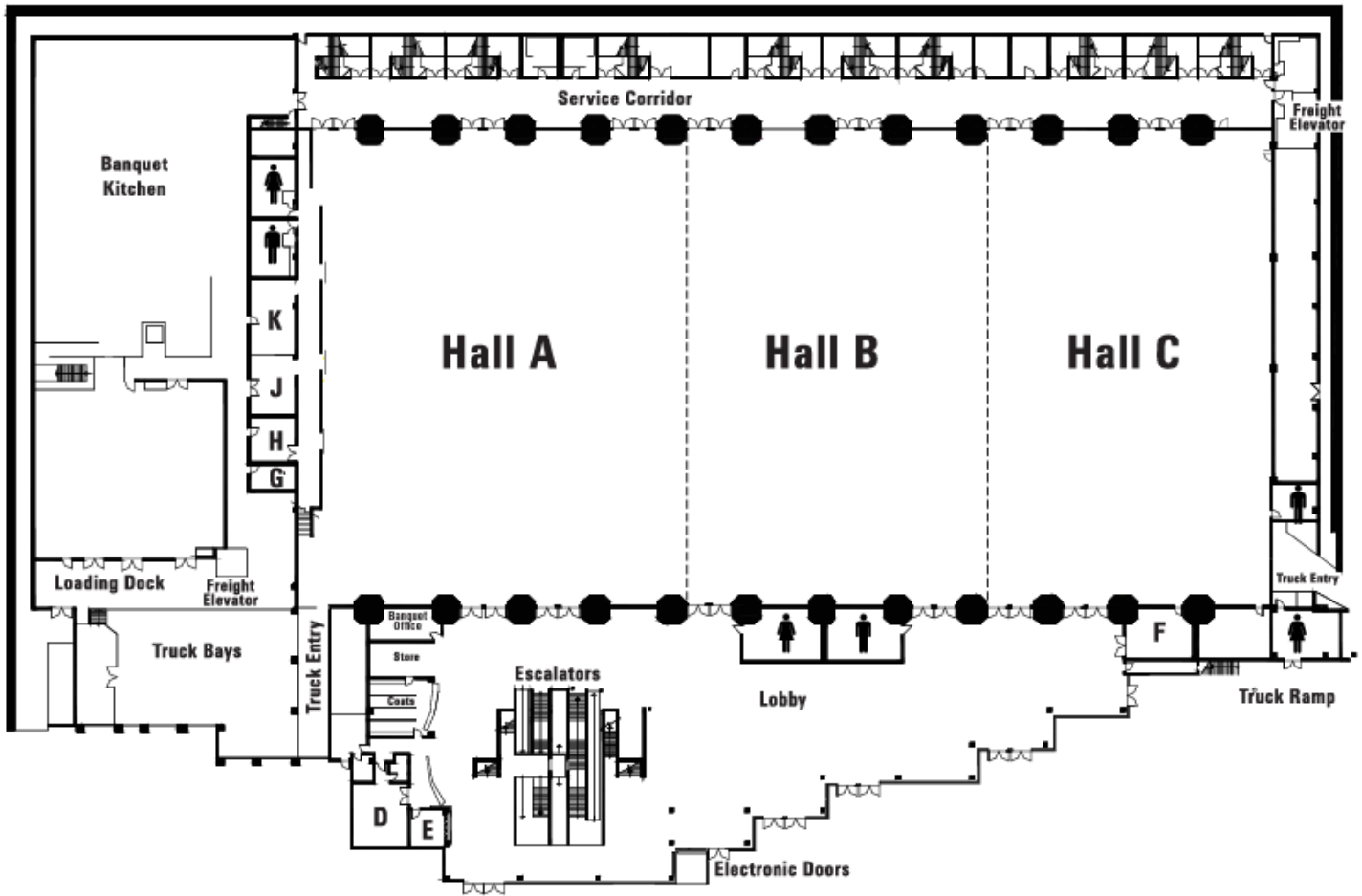

For a full Edmonton Convention Centre Facility Services Guide [Click Here!](#)

All exhibit fixtures, especially portable or “pop-up” displays, must be set-up in a manner to withstand normal contact or vibration due to outside forces such as wind, the movement of forklifts, heavy machinery or equipment and unintentional contact on the part of cleaners, laborers or neighboring exhibitors. Exhibitors using curved pop-up backdrop/displays are required to provide masking drape at their expense if the curvature exposes more than 3 feet of the back scaffolding.

If your exhibit exceeds these limits, please contact **Hayley Dalglish** with Event Management immediately at hayleydalglish@dmgevents.com.

BOOTH GUIDELINES

What exactly can my booth look like?

Event Management has guidelines in place to ensure that every exhibitor has an equal opportunity to display their products and/or services. All exhibitors are equal, regardless of booth size and should be given equal opportunity, within reason, to present their product in the most effective manner to the audience. Therefore, all exhibitors should abide by sightline guidelines to ensure their neighbors’ visibility from the aisle and vice versa.

There is no limitation on the height of equipment (if it fits within the height restrictions of the building), provided such equipment is self-supporting and free standing. There are restrictions with respect to wall height as described in booth types.

Please take the time to ensure that your display meets these regulations to prevent unnecessary work on-site.

Booth Types:

Standard Booth

One or more 10' x 10' booths in a straight line. A Perimeter booth backs against a wall of the exhibit facility rather than another exhibit. Regardless of the number of linear booths in a row, display materials should be arranged in such a manner so as not to obstruct sight lines of neighboring exhibitors. (This means that you cannot place your equipment so that it blocks the sightline of your neighbor over the side divider).

Booth Specifications

Max. Back Wall Height: 8 feet

Max. Side Wing Divider Height: 3 feet

Hanging Signage Specifications

Not attached to the top of the back wall Max.

Height of Top of Sign: 12 feet

Min. Height of Bottom of Sign: 8 feet Min. From Back of Booth: 3 feet

Min. From Neighboring Booth: 3 feet Min. From Front of Booth: 3 feet

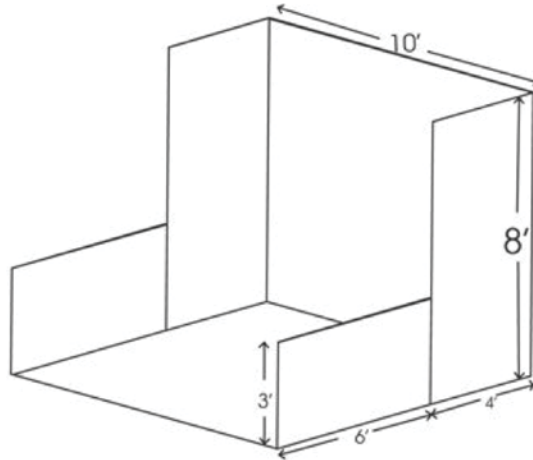

End-Cap Booth

10' x 20' booth space exposed to aisles on three sides.

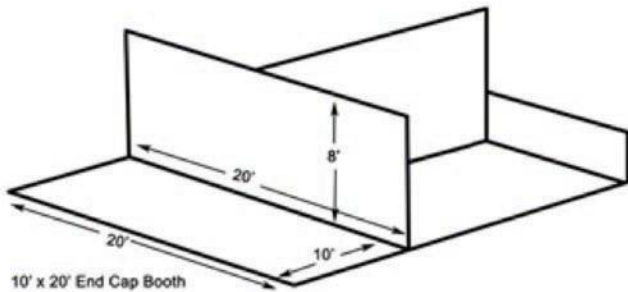

Booth Specifications

Max. Back Wall Height: 8 feet

Hanging Signage Specifications

Not attached to the top of the back wall Max.

Height of Top of Sign: 12 feet

Min. Height of Bottom of Sign: 8 feet Min. From Back of Booth: 3 feet

Min. From Neighboring Booth: 3 feet

Peninsula Booth

20' x 20' or larger booth space exposed to aisles on three sides. There are two types of peninsula booths: Peninsula abutting Standard or In-line Booth.

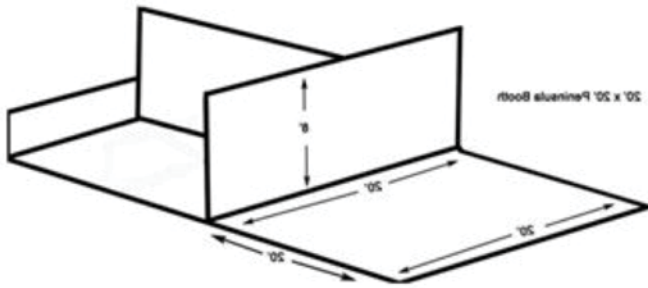

Booth Specifications

Max. Back Wall Height: 8 feet

Hanging Signage Specifications

Not attached to the top of the back wall Max. Height of Top of Sign: 12 feet

Min. Height of Bottom of Sign: 8 feet Min. From Back of Booth: 3 feet

Min. From Neighboring Booth: 3 feet

Peninsula abutting Peninsula: When a peninsula backs up to another peninsula booth, the back wall is restricted to 8' high. The backside of the wall must be finished and not contain signage or logos.

Hanging Signage Specifications

Finished on all sides, and not directly attached to the top of the back wall.

Max. Height of Top of Sign: 16' high Min.

Height of Bottom of Sign: 8' high

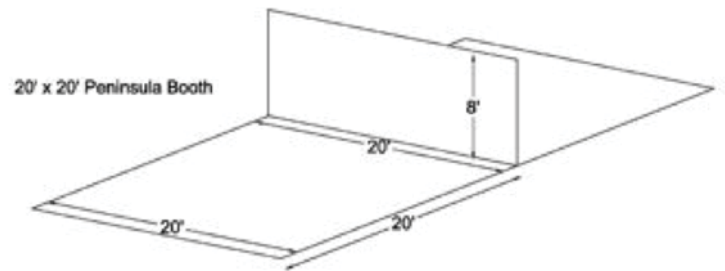

Walk-Through Booth

A walk-through booth is any booth 20' X 20' or larger that backs up to another walk-through or peninsula booth. Regardless of the number of linear booths in a row, display materials should be arranged in such a manner so as not to obstruct sight lines of neighboring exhibitors. (This means that you cannot place your equipment so that it blocks the sightline of your neighbor over the side divider).

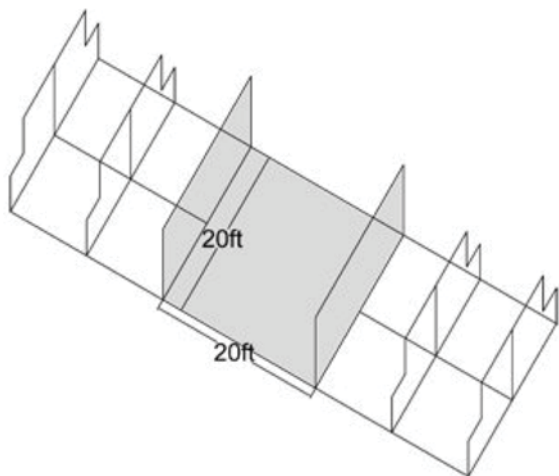

Booth Specifications

Max. Side Wall Height: 8 feet Hanging

Signage Specifications

Not attached to the top of either side wall Max. Height of Top of Sign: 12 feet

Min. Height of Bottom of Sign: 8 feet Min. From Back of Booth: 3 feet

Min. From Neighboring Booth: 3 feet Min.

From Front of Booth: 3 feet

Island Booth

A block of exhibit space with aisles on all four sides. All Hanging signs must fit between 8' and 16' from the ground. The maximum wall height permitted is 16' that, if required, must be in the internal portion of the booth and not exceed 10' in width in any direction. Perimeter walls regardless of height are not permitted in island booths. Any structure exceeding 8' in height must be approved by management and if required the proper engineering certificate must be submitted for marshal approval.

SHOW REGULATIONS

Exhibitor Appointed Contractor (EAC)

Exhibitors using the services of display firms/ independent contractors must download and submit the following EAC Approval Request form to Event Management.

Sign and Banner Hanging

Signs must be professionally designed and constructed, lightweight and in good taste. Your signs must not constitute a danger to visitors or infringe on other exhibitors. The hanging of signs and banners must adhere to the above guidelines. As per Alberta Fire Code regulations, all banners and signs must be CAN/ULD-S109 certified or proof of fire retardancy treatments must be available prior to hanging.

Signage Specifications

Hand-written signs are not permitted. Signage may be suspended, or tower mounted. Signage must be finished on all sides and be completely within the cubed boundaries of the rented space. The bottom of all signs must be 8' off the ground – top of sign height restrictions apply, please see specific signage restrictions below in each type of booth display.

ENGINEERING CERTIFICATION

Booth structures such as towers and columns that exceed 12 feet (3.66M) in height (excluding hanging signs) or two- story exhibits (any height), regardless of whether people will occupy the area or not, will require engineering certification verifying the structural integrity of the exhibit. Acceptable certification is in the form of a certified structural engineer's stamp or seal directly on your set of blueprints for the exhibit.

Failure to obtain and have available the required documentation could delay or prevent construction of your exhibit. Signs must be posted indicating the number of people the structure will accommodate. This policy has been established to ensure the safety of exhibitors and visitors at the Show.

SAFETY REGULATIONS

[The Alberta Occupational Health and Safety Board](#) requires the adherence to safety requirements governing exhibits and displays. Failure to comply with the fire and safety regulations could mean that your booth could be shut down.

FIRE REGULATIONS

1. Decorating materials, including signs, banners, plastic materials, canvas, cardboard, artificial flowers, and foliage, shall be inherently flameproof or properly treated with a flame retardant. Plastic cloth and certain other plastic materials, tar-paper, nylon, oilcloth, etc. cannot be rendered flame retardant and are prohibited. At the discretion of the Fire Department any decorative material may be subject to testing. If any item fails, the flameproof testing may be required to be removed from the building.
2. Unless otherwise approved, flammable or combustible and/or compressed gases shall not be used or displayed. Where approved cylinders containing pressed gases shall be protected against mechanical damage and shall be stored on racks or by other accepted devices designed to hold them securely in place. Combustible materials that are 10mm (3/8 inch) or more in thickness or glass may be used without flame retardant treatment. Exception: Paper, cardboard or foam products.
3. Aerosols – It is permissible to exhibit one pressurized container, not exceeding one-pint capacity of each product classified as flammable liquid.
4. All storage shall be kept in allocated areas. No empty cardboard containers are permitted to be stored in the booth space. Exits and aisles surrounding the booth space shall be clear and free of obstructions.
 - No propane cylinders are permitted in any indoor exhibits.
 - All electrical appliances, electrical cords and electrical connections shall comply with the following Electrical Codes:
 - All electrical fixtures and appliances must be approved and carry the appropriate ULC or CSA3 listing:
 - Three wire (grounded) cords shall not be plugged into two (2) wire extension cords.
 - Extension cords shall not run under carpets/rugs unless designed to be used in these locations.

MOTOR VEHICLES AND GAS POWERED EQUIPMENT

All motor vehicles and/or gasoline powered equipment used for the purpose of display indoors shall comply with the following:

- Event Management must be notified, and approval is required prior to arriving onsite.
- Fuel tanks are restricted to a maximum of ¼ (25%) full or 20L whichever is less. Fuel tanks are to be equipped with a lock-on type gasoline cap or sealed in an approved manor. Where it is not feasible to lock or seal the opening, the fuel tank shall be empty. Adding or removing fuel on site is prohibited (must be done outdoors)
- Vehicles shall not be started or operated within any assembly building during show hours.
- Batteries need NOT be disconnected.
- Keys must be removed from all vehicles.
- Vehicles, boats, RV's, trailers, and similar exhibited products having over 9.3m² of roofed area shall have a listed single station smoke alarm installed.
- Vehicles, boats, RV's, trailers, and similar exhibited products between 9.3m² and 27.9m² of roof area, with a source of ignition, external power or vehicle batteries still connected, shall have a listed single station smoke alarm installed and a 2A-10BC fire extinguisher.
- Vehicles fueled by LPG/LNG are not permitted on the exhibit floor.
- A propane-fueled vehicle may be parked indoors provided there are no leaks in the propane system and the tank is not filled beyond its maximum permitted density. This vehicle shall have the shut-off valve closed and secured to prevent tampering. Special conditional permission must be obtained prior to the vehicle entering the building.

- There shall be a sufficient clearance from lights or other heat sources to any combustible or display materials to prevent any possible ignition or heat damage (melting)
 - All electrical plugs and cords shall be free from defects. Only listed electrical devices and cords are allowed.
5. All tents, canopies and/or structures being used for the purpose of display within an indoor booth/exhibit shall comply with the following:
- Tents and canopies must be approved for indoor use and have a permanently attached label indicating conformance to CAN/ULC–S109, “Flame Tests of Flame-Resistant Fabrics and Films”. Tents or canopies without a permanently attached label may not be allowed and will be at the discretion of the Calgary Fire Department.
 - A roof, ceiling and/or other obstruction between 9.3m² (100sq.ft.) and 27.9m² (300sq.ft.) shall be provided with a listed single station smoke alarm within
 - A roof, ceiling and/or other obstruction between 9.3m² (100sq.ft.) and 27.9m² (300sq.ft.) with a source of ignition shall be provided with a listed single station smoke alarm plus a 2A-10BC fire extinguisher within
 - A roof, ceiling and/or other obstruction larger than 27.9m² (300sq.ft.) requires written approval from the Calgary Fire Department prior to set up.

If you have any questions, full details of fire regulations can be obtained from: Edmonton Fire

Department

Fire Prevention Bureau Tel:

+1(780)-496-3628

fireprevention@edmonton.ca

OCCUPATIONAL HEALTH AND SAFETY

Employers operating in Alberta must comply with the Alberta Occupational Health and Safety Act, Regulation, and Codes as applicable to their operation. Further information can be obtained from Workplace Health and Safety South region.

OHS Act, Regulation & Code

Failure to comply with occupational health & safety regulations could mean that work on setting up your booth can be shut down.

PERSONAL PROTECTION EQUIPMENT REQUIREMENTS

During move-in and move-out of the Canadian Hydrogen Convention, the exhibition floor is a “work-site environment”. Therefore, all contractors and/or exhibiting companies working within the environment must adhere to all the legislation contained within the Occupational Health & Safety Code of the Government of Alberta.

Please review the [Contractor Guide](#), published by The Edmonton Convention Centre.

SECURITY

Security guards will be on duty 24 hours a day (on a roaming basis only) from the opening of move-in to the closing of move-out. Event Management does not accept any liability for loss or damage to the exhibitor's booth or materials. All property of the exhibitor is understood to remain under the exhibitor's custody and control, whether in transit to and from or within the confines of the exhibit space.

Security Tips

During Move-In

- Use plain boxes, containers and labels that do not identify the products.
- Have adequate personnel present at the booth to receive the shipment and take inventory.
- Report any discrepancy in goods received to the shipper immediately.
- Ensure you have proper insurance coverage.
- Store valuables out of sight.

During the Show

- Pack small items in boxes out of sight or remove them from the booth overnight.
- Never leave your booth unattended. Samples or briefcases are easily taken.
- Computers, projectors, monitors, and other electronic devices are desirable to thieves. They should always be guarded.
- Report all security and safety incidents to Event Security or Event Management immediately.
- Store valuables out of sight.

During Move-Out

- Remove valuables, small cartons and open cases of products from Show area immediately upon close of the Show.
- Have proper exhibitor identification on all goods.
- Remain with your shipment until it is removed from your booth.
- Don't leave booths unattended. Many outsiders have access to the booth area during this busy time.

Keep any plasma screens, computer screens or any other electrical equipment in plain boxes, labeled with information that does not identify the product.

BOOTH STAFF & OPERATIONS

Exhibitors must ensure a fully staffed booth during Show hours. Moving in or out or dismantling will not be permitted during Show hours.

There are absolutely no forklifts or dollies allowed on aisle carpet at any time. For the safety of the public, we ask that exhibitors wait for 30 minutes after the Show closes before beginning move-out. Dismantling must not commence until 5:00 pm on Wednesday.

Exhibitors will also be expected to keep all displays and equipment within their designated space and not in the aisles. Exhibitors are specifically prohibited from employing any type of attraction that, in the opinion of the organizers, detracts from the professional nature of the Show.

Soliciting of business and/or distribution of samples and souvenirs must be confined to exhibitor's own space. Exhibitor literature found in empty booths, aisles or registration areas will be removed and disposed of.

SOUND SYSTEMS / NOISE LEVELS

The Canadian Hydrogen Convention has established the following rules and regulations for all exhibitors to ensure that any featured equipment, presentations, demonstrations, simulations, or devices producing noise or odors, shall not disturb neighboring exhibitors or visitors of the Show:

- Any equipment, presentations, demonstrations, simulations, or devices producing noise or odors that disturb neighboring exhibitors or visitors will not be tolerated.
- All noise originating from an exhibit must always be set at a reasonable level and shall not exceed 60 decibels (Indoors) and 85 decibels (outdoors).
- Any complaint(s) of excessive noise originating from an exhibit, reported to Show Management, will be pursued and assessed. If assessed to be disturbing or disruptive, the exhibitor will receive one (1) written warning and be asked to reduce the noise level immediately.
- If after one (1) warning by Show Management, the offending exhibitor does not reduce the level of sound, Show Management, at its discretion, may elect to shut off the power to the offending portion of the exhibit. The exhibitor will be responsible for any charges related to this action.
- Any speaker(s) or sound equipment within an exhibit must be positioned to minimize the amount of noise or distraction towards aisles and neighboring exhibits.
- Any audio or visual productions being played within an exhibit must be positioned to minimize the amount of noise or distraction towards aisles and neighboring exhibits.
- No singing, dancing, use of musical instruments or other types of live performances, presentations, demonstrations or simulations are permitted to occur at the show without expressed written permission from Show Management.

If your exhibit exceeds these limits, please contact **Hayley Dalgleish** with Event Management immediately at hayleydalgleish@dmgevents.com.

DOS – CREATING AN ATTRACTIVE DISPLAY

- **KEEP IT SIMPLE.** Upon first glance, your booth should tell visitors who you are and what you do.
- Give your customers room to move around in your booth.
- Keep your space open and inviting, so visitors can enter/exit easily.
- If space allows, set aside a meeting area within your booth and stock it with refreshments.
- Offer demonstrations within your booth.
- Ensure booth staff is dressed professionally.
- Have enough booth staff to allow for breaks, but not so many that you deter people from entering.
- Ensure you start each day with a clean booth.
- Reduce tired feet by ordering carpet underlay in your booth. (Both your clients and staff will appreciate the extra touch!)
- **BE INFORMED** – not only about your company and products, but also know where to find restrooms, food vendors, lounges, and ATM's. Customers will ask lots of odd questions.
- Qualify potential buyers by talking to them first before handing out company literature.
- Keep brochures and literature at the back of the booth, not at the front where customers can grab it quickly.
- Offer to send brochures to the customers after the event.
- Have plenty of business cards on hand.

DO NOTS - CREATING AN ATTRACTIVE DISPLAY

- Confuse visitors with too much detail or clutter. Your graphics should communicate the major points while booth staff can go into more detail.
- Trap visitors in your booth. If your booth is preventing people from leaving, it is also preventing people from entering.
- Cram your booth with too much furniture or booth staff. A few stools, a display table or counter, and location to do business are enough. Space encourages interaction with your customers.
- Crowd your booth with too many products and brochures. Your display is meant to stimulate interest, not show your entire product line.
- Eat, sit and read the paper or work on your computer or phone. Booth staff should be interested and welcoming. You only get out of exhibiting what you put into it at the event.
- Leave your booth unattended.